

### Application

The 4115W is a powered full-range, two-way system designed for a wide variety of speech and music applications, such as clubs, churches, or concert settings.

### Amplification

The 4115W is a Modular System. While it is sold and shipped as a Powered Product it can also be purchased without the amplifier to be upgraded later. The Amplifier is a revolutionary 400 watt "transformerless" amp that is optimized for each cabinet in the Series 4000. It weighs less than 3 lbs.

### Cabinetry

The cabinet design uses a 13 ply 3/4" (18mm) high quality baltic birch plywood with dado joints, recessed baffle and a 16 gauge front perforated grill for long lasting durability. The baffle is cut from 1" MDF to enhance acoustical properties and to give the components a rigid interface. While it is shipped standard in Duracoat Black it is also available in white and natural birch finish.

### Transducers

The two-way cabinet is loaded with a 15" cast aluminum low frequency driver and a 1" titanium high frequency compression driver. The titanium high frequency driver is coupled with a durable ABS horn for proper dispersion. The cabinet is tuned by means of a vented port set at the optimum frequency.

### High Frequency Protection

The 4000 Series features our exclusive "OPC" system (patent pending) with LED indicators mounted on the baffle. A green LED which lights when there is signal present - and a red LED which lights when the OPC (overload protection circuitry) senses an overload condition in the HF driver. The OPC turns down (-10dB) the HF driver temporarily, and the red LED flashes, indicating an overload. When the HF driver cools, or the power is decreased, the OPC automatically resets itself and signal is restored to the HF driver.



### Specifications

<b>Frequency Response:</b>	55Hz-18kHz
<b>Power Handling:</b>	400w (cont.)
<b>Sensitivity (1 watt/meter):</b>	99dB
<b>Nominal Dispersion:</b>	110H x 70V
<b>Impedance:</b>	8 Ohms
<b>Transducer Components</b>	
Low Frequency:	15" woofer
High Frequency:	1" titanium
<b>Audio Input Connections:</b> Two Neutrik Speakon connectors and two Neutrik 1/4" jacks.(passive) One XLR Male/ One Female (active)	
<b>Enclosure:</b>	Vented
<b>Crossover:</b>	1600Hz
<b>High Frequency Protection:</b>	Yes
<b>Steel Pole Mount:</b>	N/A
<b>Physical</b>	
Dimensions (H x W x D):	19.25" x 17.6" x 24.25" (48.9cm x 44.8cm x 61.6cm)
Weight:	58 lbs./26.4 Kg

### Warranty Information

The 4000 Series high definition speakers feature a 10 year warranty on the components and enclosure and a 3 year warranty on the amplifier. Please refer to the warranty information card shipped with all Sound Bridge speaker products.



### Modular Design

SERIES 4000 models use true open architecture allowing them to function as powered full-range, passive full-range or bi-amplified cabinets. Each model in this family has spaces for modules including a contour module, mic pre module, mini-mixer module, and a delay module. See pricing and literature for information on available modules.

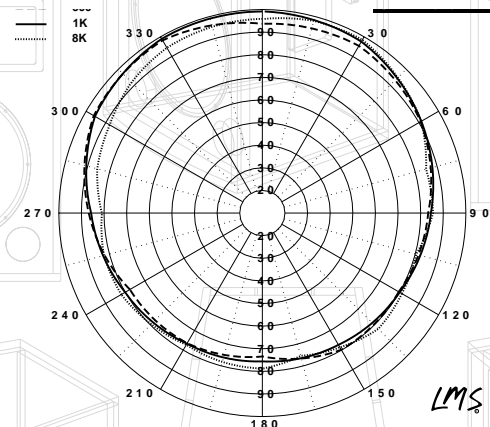
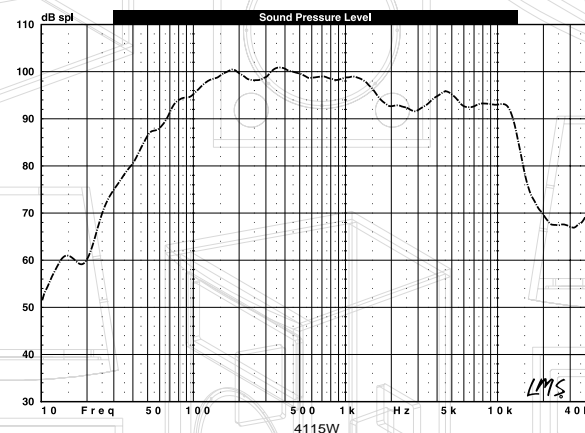
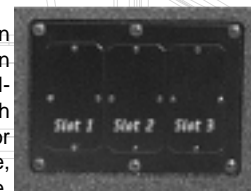

3501 Interstate 35E • Waxahachie, TX 75165 • 800 628-9084 • FAX (972) 935-0539

Sound Bridge Acoustic Labs is dedicated to excellence. Therefore, we retain the right to improve design, materials and workmanship. (Or in legal jargon: Prices and Specifications are subject to change without notice.)